



At the heart of your home

REGENT L.F.E. RC

LIVE FUEL EFFECT CONVECTOR GAS FIRE

Installation, Maintenance & User Instructions

Hand these instructions to the user

Model No's FRLCP0RN2 & FRLCN0RN2 are for use on Natural Gas (G20) at a supply pressure of 20 mbar in G.B. / I.E.

Information Requirements for Commission Regulation (EU) 2015/1188

Model Identifier	FRLC**RN2
Indirect Heating Functionality	No
Direct Heat Output	3.3kW
Indirect Heat Output	Not Applicable
Fuel	Natural Gas (G20)
NOx Emissions	130mg/kWh
Nominal Heat Output	3.3kW
Minimum Heat Output (Indicative, all models)	0.9kW
Useful Efficiency at Nominal Heat Output	59.3%
Useful Efficiency at Minimum Heat Output (Indicative)	50.0%
Auxilliary Power Consumption at Nominal Heat Output	0.000001kW
Auxilliary Power Consumption at Minimum Output	0.000001kW
Auxilliary Power Consumption at Standby Mode	0.000001kW
Permanent Pilot Flame Requirement	Not applicable
Type of Heat Output / Room Temperature Control	Two or more manual stages, with no room temperature control.
Contact Details	BFM Europe Ltd. Gordon Banks Drive Trentham Lakes North Stoke-on-Trent ST4 4TJ Tel : 01782 339000

CONTENTS

	PAGE
Section 1 Information and Requirements	
1.0 Appliance Information	3
1.1 Conditions of Installation	4
1.2 Flue & chimney suitability	4
1.3 Fireplace / surround suitability	5
1.4 Shelf position	5
1.5 Side clearance	5
1.6 Closure plate	5
1.7 Flue & chimney inspection	5-6
1.8 Chimney / flue type information	6-7
1.9 Hearth information	8
1.10 Spillage monitoring system	8
Section 2 Installation of Fire	
2.1 Packing check list	9
2.2 Installation of fire	9-10
2.3 Gas connection	11
2.4 Fitting the fuel-bed	11-12
2.5 Gas tightness	12
Section 3 Fitting the Batteries, Lighting the Fire & Commissioning	
3.1 Fitting the batteries	13
3.2 Lighting the fire manually via the control valve	14
3.3 Setting the time and date on the remote handset	15-18
3.4 Lighting the fire - remote control models	19-22
3.5 Advanced settings of remote control models	22-24
3.6 Checking for clearance of combustion products	27
3.7 Final checks	28
Section 4 Maintenance	
4.1 General access for servicing	29
4.2 Removal of the burner assembly	30-31
4.3 Removal of the remote control valve	32
4.4 Removal of the pilot assembly	32-33
4.5 Parts shortlist	33
Section 5 User Instructions	
5.1 Installation Information / about your fire	34-36
5.2 Operating your fire	37-40
5.3 Manual operation	41-42
5.4 Replacing batteries	42
5.5 Setting the time, date & temperature on the remote control handset	43-46
5.6 Advanced settings menu of the remote control	47-51
5.7 Cleaning	51
5.8 Removal / re-fitting the fuel-bed ceramics	52
5.9 User replaceable parts	53

1.0 APPLIANCE INFORMATION

Main injector (1 off)	Size 420, Cat 82
Pilot type	ERTA OXYP PG-83-10
Max. Gross Heat Input :	6.1 kW
Min. Gross Heat Input :	1.8 kW
Cold Pressure :	20.0 +/- 1.0 mbar (8.0 +/- 0.4 in w.g.)
Ignition :	4.5V battery / electronic ignition
Electrode Spark Gap :	4.0 mm
Weight (Packed) :	22.0kg

Firebox Dimensions (with case fitted)

Width :	710mm
Height : (without feet fitted)	680mm
Depth :	255mm
Height to top of the flue spigot :	420mm (with feet fitted)
Gas Connection :	8mm compression (Supplied with fire)

Efficiency Declaration

The efficiency of this appliance has been measured as specified in BS 7977-1 : 2009 + A1 2013 and the result is 54%.

The gross calorific value of the fuel has been used for this efficiency calculation.

The test data from which it has been calculated has been certified by BSI.

The efficiency value may be used in the UK Government's Standard Assessment Procedure (SAP) for energy rating of dwellings.

1.1 CONDITIONS OF INSTALLATION

In Great Britain :-

It is law that all gas appliances are installed only by a GAS SAFE registered installer in GB, in accordance with these installation instructions and the Gas Safety (Installation and use) Regulations 1998. Failure to install appliances correctly could lead to prosecution. It is in your own interest and that of safety to comply with the law.

The installation must also be in accordance with all relevant parts of the Local and National Building regulations where appropriate, the Building Regulations (Scotland Consolidation) issued by the Scottish Development Department, and all relevant recommendations of the following British Standard Code of Practice.

1. BS 5871 Part 1. Installation of Gas Fires.
2. BS 5440 : 2000 Parts 1 & 2. Installation of Flues & Ventilation.
3. BS 6891 Installation of Gas Pipework.
4. BS 6461 Part 1. Installation of Chimneys & Flues.
5. BS 1251 Open Fireplace Components.
6. BS 715. Metal Flue pipes for Gas Appliances.
7. BS 1858 Clay Flue blocks and Terminals.
8. BS 7566 Installation of factory-made Chimneys.

Ventilation Requirements

For use in G.B. purpose built ventilation is not normally required for this appliance.

In Republic of Ireland :-

For use in I.E. this appliance must be installed in accordance with the rules in force by a competent person and used only in a sufficiently ventilated space. Please consult document *I.S. 813 : 1996 Domestic Gas Installation*, issued by the National Standards Authority of Ireland.

1.2 FLUE AND CHIMNEY SUITABILITY

The appliance is designed for use with conventional brick built chimneys or lined chimneys and pre – fabricated flues. It is also suitable for use with pre-cast flue blocks conforming to BS EN 1858 and metal flue boxes conforming to BS 715. All flues must conform to the following minimum dimensions.

Minimum diameter of circular flues	125 mm
Minimum effective height of all flue types	3 metres
Minimum cross sectional area of Pre-cast Flues	16,500mm²

1.3 FIREPLACE / SURROUND SUITABILITY

The fire is suitable for hearth mounting only. It must **not** be fitted directly onto a carpet or other combustible material. It must **not** be wall mounted.

This fire is suitable for the following hearth / surround types :-

Non-combustible hearths / surrounds.

Purpose made proprietary hearths / surrounds with a minimum temperature rating of 100°C.

If a heating appliance is fitted directly against a wall without the use of a fireplace or fire surround, soft wall coverings such as wallpaper, blown vinyl, etc. could be affected by the heat and may, therefore scorch or become discoloured. Please bear this in mind when installing or decorating.

1.4 SHELF POSITION

The fire may be fitted below a combustible shelf providing there is a minimum distance of 100 mm above the top of the fire and the shelf does not project more than 150 mm. If the shelf overhangs more than 150 mm the distance between the fire and the shelf must be increased by 25 mm for every 25 mm of additional overhang over 150 mm.

1.5 SIDE CLEARANCE

A minimum clearance of 100mm should be allowed on either side of the fire for servicing. Any fire surround uprights should not project forward by more than 100mm.

NOTE. The fire must be installed so that no part of a combustible side wall when measured laterally is less than 500mm from the fuelbed ceramics.

1.6 CLOSURE PLATE

A closure plate is supplied with this fire and **must** be fitted. The closure plate must be sealed to the fireplace or surround opening with suitable adhesive tape. See section 2.2.2

1.7 FLUE / CHIMNEY INSPECTION

Before commencing installation, a flue or chimney should be inspected to ensure that all the following conditions are satisfied.

- 1.7.1 Check that the chimney / flue only serves one fireplace and is clear of any obstruction. Any obstruction. Any dampers or register plates must be removed or locked in the open position.

- 1.7.2 Brick / stone built chimneys and any chimney or flue which has been used for an appliance burning fuel other than gas must be thoroughly swept. The base of the chimney/flue must also be thoroughly cleared of debris etc.

Any under floor air supply to the fireplace must be completely sealed off.

Ensure that the inside of the chimney/flue is in good condition along its length and check that there is no leakage of smoke through the structure of the chimney during and after the smoke pellet test.

With pre-cast flues it is especially important to check the inside of the flue for extruded cement / sealant protruding from the joints between the flue blocks. If present, these should be removed by rodding the flue before proceeding with the installation.

Using a smoke pellet, check that there is a positive up draught present in the chimney / flue and that the smoke can be seen issuing from the terminal / chimney pot outside. There must be no leakage of smoke through the structure of the chimney during or after the smoke pellet test and it is important to check inside upstairs rooms adjacent to the chimney / flue. Check the chimney pot / terminal and general condition of the chimney brickwork or masonry. If the chimney or flue is in poor condition or if there is no up draught do not proceed with the installation. If there is a history of down draught conditions with the chimney / flue, a tested and certified flue terminal or cowl suitable for the relevant flue type should be considered.

A spillage test must always be carried out during commissioning of the appliance.

1.8 CHIMNEY INFORMATION

1.8.1 Brick Built Chimneys.

The catchment space below the flue spigot should be as deep as possible, and must not be less than 250mm measured from the bottom of the flue spigot to the bottom of the catchment space, or to the top of any "bricking-up" of the fireplace, whichever is the least. See figure 1 overpage.

The flue spigot must pass through the closure plate at least 25mm and have a minimum clearance of 50mm between its open end and the nearest obstruction. There must be a minimum clearance of 165mm between the back of the closure plate and the back of the catchment space. See figure 1 overpage.

The front opening of the fireplace must be between 305mm and 440mm wide, and between 525mm and 650mm high. If the opening is larger than this, then a surround must be constructed in a suitable non-combustible material to create an opening to these limits. Allow a minimum flat surface of 20mm around the opening to ensure that the closure plate can be sealed to the fireplace.

Any surround must be sealed to the fireplace to prevent leakage. The operation of the chimney should be tested as detailed as in section 1.7.

Note. A flue spigot extension of up to a maximum total length of 125mm may be fitted if necessary, providing that a minimum clearance 50mm between its open end and nearest obstruction is always maintained.

Fig.1. Chimney Catchment Space.

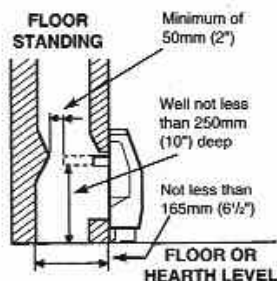

1.8.2 Fitting to Pre-Fabricated twin wall metal Flue Boxes.

The appliance may be fitted to a twin wall metal flue box conforming to the constructional requirements of BS 715, (for example the Selkirk LFE 125 box). The box must have a minimum flue diameter of 125mm internal and minimum internal dimensions of 160mm deep by 580mm high by 350mm wide. There are no maximum dimensional requirements for the box. The top face of the box must be insulated with a minimum thickness of 50mm of non-combustible mineral wool insulation or similar material. The flue box must stand on a non-combustible base of minimum thickness 12mm.

1.8.3 Fitting to Pre-Cast Flue Installations.

The pre-cast opening must be a minimum of 16,500mm² in cross-sectional area and have a minimum effective flue height of 3 metres. The flue spigot restrictor must be removed when installing into pre-cast flue applications. **This appliance has been tested for use in a pre-cast flue block complying with BS EN 1858. In accordance with BS EN 1858, pre-cast flues built with directly plastered faces (front or rear) are not correctly installed as to ensure proper operation with any type of gas fire. In some instances of this flue construction, temperature cracking of surface plaster may occur through no fault of the appliance. An air gap or some form of insulation material should be installed to prevent normal flue temperatures from damaging wall surfaces.**

1.9 HEARTH INFORMATION

This appliance must only be installed on to a level concrete or non-combustible hearth. The feet must not be removed when installing directly onto a hearth. The hearth material must be a minimum thickness of 13 mm with the top surface at least 50 mm above the floor level. The hearth **must** be fitted symmetrically about the fire opening and have a minimum width of 760 mm and a minimum projection of 300 mm forwards from the fire opening.

1.10 SPILLAGE MONITORING SYSTEM

This appliance is fitted with an atmosphere sensing spillage monitoring system in the form of an oxygen sensing pilot. This is designed to shut the fire off in the event of partial or complete blockage of the flue causing a build up of combustion products in the room in which the fire is operating. **The following are important warnings relating to the spillage monitoring system:**

The spillage monitoring system must not be adjusted by the Installer. The spillage monitoring system must not be put out of action. When the spillage monitoring system is exchanged, only a complete original Manufacturers part may be fitted. It is not possible to replace individual parts on the pilot system on the appliance, only a complete pilot assembly (including thermocouple) may be fitted.

2.1 PACKING CHECK LIST

- 1 off firebox / burner assembly
- 1 off efficiency baffle & 4 off screws fitted to rear of fire
- 1 off closure plate (fitted to fire)
- 1 off literature / loose Items pack including dress guard
- 1 off fuelbed pack (rear section & front section)
- 1 off flue spigot
- 1 off thermostatic remote control handset
- 5 off AA batteries
- 1 off guarantee card
- 1 off dress guard
- 1 off Installation / user manual (combined)

2.2 INSTALLATION OF FIRE

- 2.2.1 The product is supplied with the dress guard as a loose item, see figure 2 below for details of how to remove & re-fit the dress guard. Take care not to scratch the trims when fitting the dress guard.

Fig. 2 Removal & Re-fitting the Dress Guard.

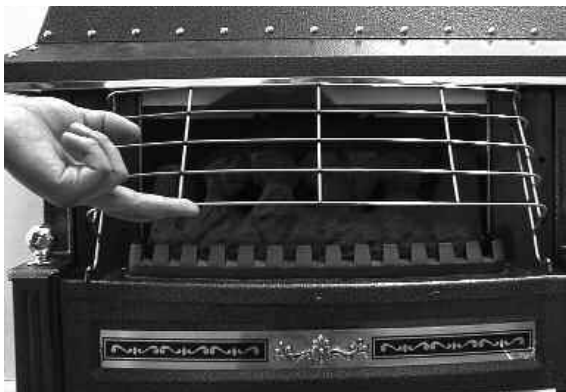

- 2.2.2 Fit the flue spigot to the back panel using four screws provided.

Closure plate.

- 2.2.3 Fit the closure plate to the fireplace opening and ensure that it has a flat sealing area of at least 10mm sealed on all sides. See figure 3 below
Dimensions stated are for closure plate supplied
Check the operation of the chimney as follows:-

Fig. 3

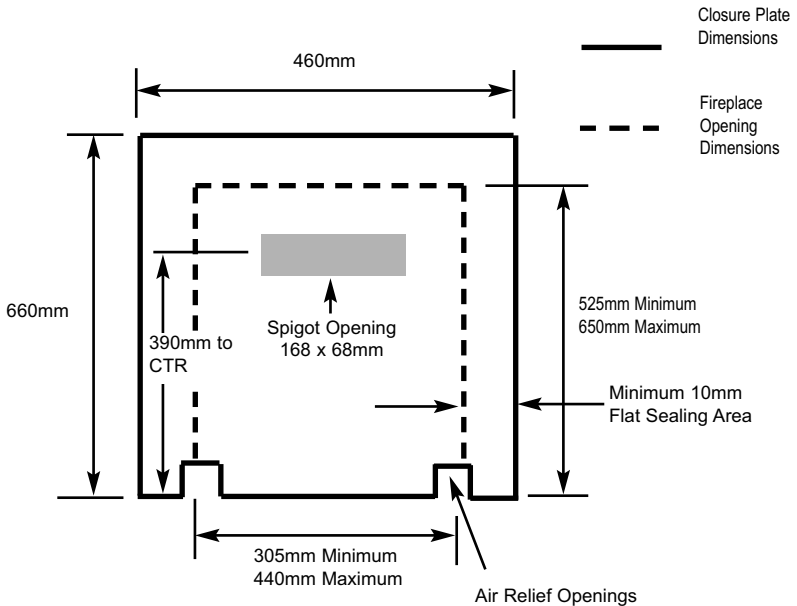

- 2.2.4 Apply a smoke match to the flue spigot opening in the closure plate and observe the smoke. If there is a definite flow into the opening then proceed with the installation. If there is not a definite flow into the opening, pre-heat the chimney for about two minutes and retest for flow. If there still is no definite flow into the opening, the chimney may require attention. DO NOT FIT THE FIRE-SEEK EXPERT ADVICE.

2.3 GAS CONNECTION

Note : A means of isolation must be provided near to the appliance to facilitate servicing.

- 2.3.1 Ensure that the gas supply is turned off before commencing. The gas connection should be made to the appliance inlet elbow using 8 mm rigid tubing. The gas connection can be made left hand, right hand or rear. In line with current installation regulations, a restrictor should be fitted to the inlet pipework to isolate the appliance for servicing and repair purposes.

Before making the final gas connection, thoroughly purge the gas supply pipe work to remove all foreign matter, otherwise serious damage may be caused to the gas control valve on the fire.

2.4 FITTING THE FUELBED

- 2.4.1 Fit the rear fuelbed section to the combustion chamber, locating behind the support bracket as indicated below in figure 4.

Fig. 4



Fit rear section of fuelbed behind support bracket as shown

- 2.4.2 Fit the front section of the fuelbed to the combustion chamber, locating behind the front casting as shown overpage in figure 5.

Fig. 5



Fuelbed front section fits behind the front casting as shown

2.4.3 Refit the dress guard.

2.5 GAS TIGHTNESS

2.5.1 Remove the pressure test point screw from the inlet elbow and fit a manometer.

2.5.2 Turn on the main gas supply and light the fire as described in section 3.2 and carry out a gas tightness test.

2.5.3 Check that the gas pressure is 20.0 mbar (± 1.0 mbar), (8.0 in w.g. ± 0.4 in w.g.)

2.5.4 Turn off the fire, remove the manometer and refit the pressure test point screw. Check the pressure test point screw for gas tightness with the appliance turned on using a suitable leak detection fluid or detector.

3.1 FITTING THE BATTERIES

3.1.1 The control valve is located at the base of the fire, remove cover plate (held by magnets) for access as shown below in figure 6.

Fig 6

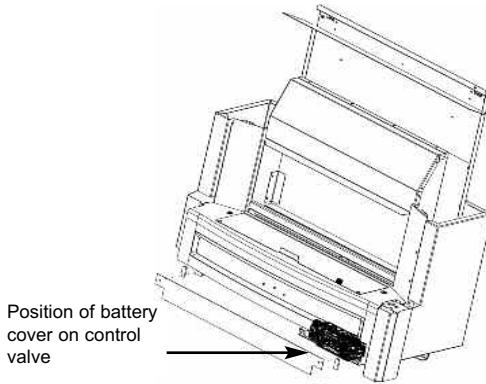

3.1.2 Remove the battery compartment cover from the control valve as indicated below in figure 7 and fit the 3 off AA sized alkaline batteries supplied to the control valve unit.

3.1.3 Ensure that the power isolation switch is in position "1" and the power indicator light is illuminated (red) after the batteries have been fitted as shown in figure 7 below.

Fig. 7

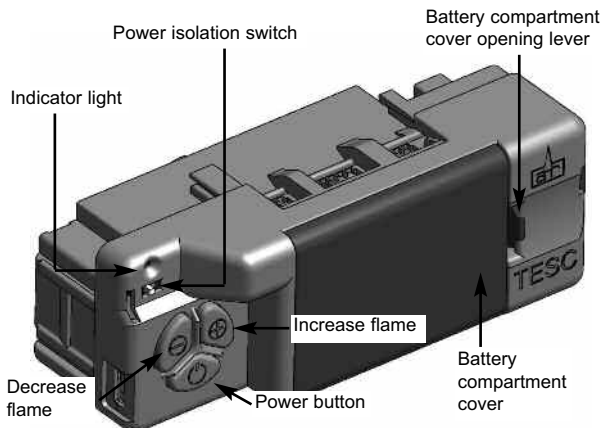

IMPORTANT NOTE : THE BATTERIES SHOULD BE REPLACED WITH GOOD QUALITY ALKALINE BATTERIES WHEN REQUIRED, THE BATTERY LIFE IS EXPECTED TO BE A MINIMUM OF 12 MONTHS WITH NORMAL USAGE. FOR BEST PERFORMANCE BFM EUROPE RECOMMEND THE USE OF ENERGIZER BATTERIES WITH IT'S PRODUCTS.

3.2 LIGHTING THE FIRE MANUALLY VIA THE CONTROL VALVE

3.2.1 These products can be operated manually by using the buttons directly on the fire control in addition to the handset (should the need arise).

3.2.2 To operate the fire press and hold the “power” button as shown below in figure 8 for two seconds, release as soon as the red indicator light shown in figure 8 illuminates. The burner will then start its ignition sequence and light to the maximum heat input level. **For most efficient performance leave the fire on high when lighting from cold for ten minutes.**

Fig. 8

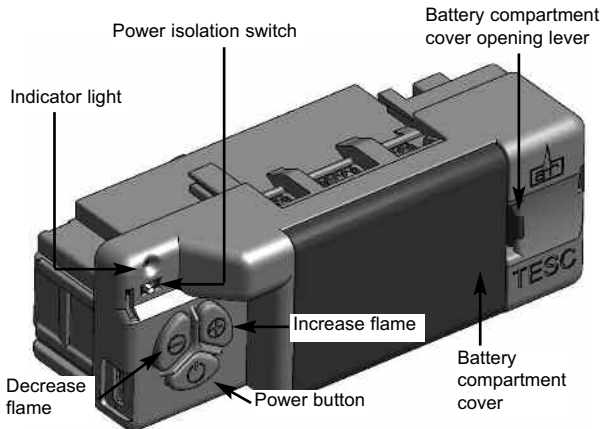

3.2.3 To reduce the heat input, press and release the (-) button to lower the heat input level one step at a time. Pressing the (-) button continuously will move the heat input level to the minimum.

3.2.4 To increase the heat input level, press then release the (+) button to increase the heat input level one step at a time. Pressing the (+) button continuously will move the heat input level to the maximum.

3.2.5 To turn the fire off, press the power button and the burner will stop.

3.2.6 **If you are not intending to use the fire for a long period (i.e. over the summer months) the battery life can be extended by sliding the power isolator switch to the left (to the “0” position away from the “1” position) on the valve itself, which is located under the front right of the fire behind the removeable cover plate on the top left corner of the control valve.**

3.3 SETTING THE TIME, DATE & TEMPERATURE ON THE REMOTE HANDSET

3.3.1 Fit the 2 off AA batteries to the handset by removing the cover on the rear of the handset and inserting the batteries, ensure the correct +/- polarity is observed. Following insertion of the batteries the screen displayed will be as shown below in figure 9.

Fig. 9



3.3.2 Hold the handset with one hand ensuring your hand is wrapped around the back and that your hand is in contact with both sides of the handset. The green light of the “unlock” symbol should light and the screen displayed will be as shown overpage in figure 10.

3.3.3 The “H” symbol as indicated in figure 10 overpage indicates that the timer can now be set in either 24hr or 12hr mode. Press the + or - buttons on the handset to toggle between the two settings, figure 10 overpage displays the 24hr mode.

Fig. 10



3.3.4 When the 24hr or 12hr time display option has been chosen and you are ready to confirm the setting you want press the SET button on the handset to progress to setting the day of the week as shown overpage in figure 11.

3.3.5 Press and release the + and - buttons on the handset until the correct day of the week is shown on the handset display

Mo = Monday
Tu = Tuesday
We = Wednesday
Th = Thursday
Fr = Friday
Sa = Saturday
Su = Sunday

3.3.6 Press SET to accept the day of the week and progress to setting the hour of the day.

Fig. 11



3.3.7 As shown above in figure 11 the time on the handset can now be set by using the + and - buttons to change the hour to the correct hour then press SET to store and to move to setting the minute. Repeat this process for setting the minute to the correct minute then press SET to store.

3.3.8 The handset will then display the temperature setting screen as shown overpage in figure 12, the option to choose either Celsius or Fahrenheit can be chosen, these settings are shown as either C or F. Use the + and - buttons to toggle between these two options then press SET to store. The important settings have now been completed so press and hold the SET button for a few seconds and this will exit the set-up menu.

Fig. 12



3.3.9 The control is now ready for use with the burner.

3.3.10 If the handset is misplaced you can “page it” by pressing the (+) button only on the control valve on the fire for a period of 5 seconds. The handset will flash and make an audible noise to help you locate it. Once you find the handset with one hand ensure your hand is wrapped around the back and that your hand is in contact with both sides of the handset then the audible noise will cease. The flashing and sound will last for 60 seconds each time the handset is paged as described. If not found in 60 seconds page the handset again until located.

3.4 LIGHTING THE FIRE - REMOTE CONTROL MODELS

3.4.1 Ensure valve power isolation switch is in the on position - see figure 8 and that the time, date & temperature display settings as shown in section 3.3 have been completed. Hold the handset with one hand ensuring your hand is wrapped around the back and that your hand is in contact with both sides of the handset. The green light of the “unlock” symbol should be lit. See figure 13 below.

Fig. 13



3.4.2 Press and hold the power button continuously until the word “PILOT” appears at the bottom left of the display as shown overpage in figure 14, (this typically takes two seconds). The burner will now light at maximum heat input level and will display “MAX” in the bottom left hand side of the display as shown in figure 15 overpage.

NOTE : If the power button is pressed for too long or too short a time or the grip on the handset is not firm or is released too soon, the lighting sequence will be interrupted and not complete. The reason for the remote control having this strict start sequence is for safety reasons so that the starting operation of the fire will be most unlikely to be done other than intentionally by an adult.

Fig. 14 - "PILOT" displayed



"PILOT" displayed on handset during ignition sequence (typically takes two seconds)

Fig. 15 - "MAX" & large flame symbol displayed



"MAX FLAME" displayed on handset when burner is lit to maximum rate

3.4 LIGHTING THE APPLIANCE - REMOTE CONTROL MODELS (CONTINUED)

3.4.3 To decrease the heat input level of the burner hold the handset as described in section 3.4.1 to unlock the keypad then press and release the - button. Pressing and releasing the - button will lower the heat input level one step at a time. Pressing the - button continuously will move the heat input level to the minimum, see figure 16 below.

Fig. 16



3.4.4 To increase the heat input level of the fire's burner hold the handset as described in section 3.4.1 to unlock the keypad then press and release the + button. Pressing and releasing the + button will increase the heat input level one step at a time. Pressing the + button continuously will move the heat input level to the maximum.

3.4.5 To turn the fire off hold the handset as described in section 3.4.1 to unlock the keypad then press and release the power button. The burner will go out.

3.4.6 **If you are not intending to use the fire for a long period (i.e. over the summer months) the battery life can be extended by sliding the power isolator switch to the left (to the “0” position away from the “1” position) on the valve itself, which is located under the front right of the fire behind the removeable cover plate on the top left corner of the control valve.**

3.4.7 **In the event of loss of the remote handset, as a backup the fire can be controlled from the valve, which is located behind the ashpan cover on the fire, see section 3.2 for full manual operating instructions. If your fire does not operate manually please consult the troubleshooting chart on the rear page of this manual.**

3.4.8 If the handset is misplaced you can “page it” by pressing the (+) button only on the control valve on the fire for a period of 5 seconds. The handset will flash and make an audible noise to help you locate it. Once you find the handset with one hand ensure your hand is wrapped around the back and that your hand is in contact with both sides of the handset then the audible noise will cease. The flashing and sound will last for 60 seconds each time the handset is paged as described. If not found in 60 seconds page the handset again until located.

3.5 ADVANCED SETTINGS MENU OF THE REMOTE CONTROL

3.5.1 Snooze mode in manual operation

3.5.1.1 Snooze mode is a time period which can be set which will turn the fire automatically off after a certain time period has elapsed.

3.5.1.2 Hold the handset with one hand ensuring your hand is wrapped around the back and that your hand is in contact with both sides of the handset. The green light of the “unlock” symbol should light. The snooze time period can be set either before or during manual operation of the fire.

3.5.1.3 With the handset held as described above, press the mode button to scroll through the functions until the symbols MAN and Zzz are flashing at the top of the display as shown overpage in figure 17.

3.5.1.4 Press and release the set button and this will put the control into the manual snooze mode.

3.5.1.5 The default time period in snooze mode is 1:00 hour.

Fig. 17



- 3.5.1.6 Pressing the set button again will now show you the snooze time period remaining. The snooze time period can be adjusted by pressing the + or - buttons on the handset. This time period can be set ranging from 1 minute to 4:00 hours.
- 3.5.1.7 To adjust the snooze period, hold the handset with one hand ensuring your hand is wrapped around the back and that your hand is in contact with both sides of the handset. The green light of the “unlock” symbol should light. Press the set button and the screen will show how long is left of the snooze period as shown overpage in figure 18.

Fig. 18



- 3.5.1.8 To adjust the snooze period use the + and - buttons to increase or decrease the snooze period for any period between 1 minute and 4:00 hours.
- 3.5.1.9 When the correct snooze period is indicated on the handset, press the set button to store the required time period, or alternatively the handset can be left for a few seconds and the period will be stored automatically.
- 3.5.1.10 When the countdown timer for the snooze period has reached zero the fire will turn off (as if you had turned the fire off manually).

3.5.2 Thermostatic mode

PLEASE NOTE : Thermostatic mode of this fire will only allow regulation of the room temperature by the fire when it has been already lit via manual operation of the handset. It will not allow the fire to light automatically due to low ambient room temperature and should therefore not be relied upon for frost protection purposes.

3.5.2.1 Hold the handset with one hand ensuring your hand is wrapped around the back and that your hand is in contact with both sides of the handset. The green light of the “unlock” symbol should light.

3.5.2.2 With the handset held as described above, press and release the mode button several times as necessary until the display has the thermometer symbol flashing at the top of the display. Press the set button to enter this mode, as shown below in figure 19.

Fig. 19



3.5.2.3 Press the set button again to see the temperature setting that is set (the default is 24 degrees celsius). If a different set temperature is required, whilst the display is showing this set temperature, press the + and - buttons to alter this setting, press the set button to store the required temperature, or alternatively the handset can be left for a few seconds and the temperature will be stored automatically.

3.5.2.4 If at any time the power button is operated during thermostat mode the control will cancel any thermostat operation and return the control to manual mode.

3.5.2.5 **IMPORTANT NOTE : Thermostat mode will not light the fire automatically and will only regulate between the maximum and minimum burner setting. The fire must be lit manually via the handset and then you enter thermostat mode as described in this section and set the temperature. When no longer requiring thermostat mode turn off the burner and the handset will return to manual mode.**

3.6 CHECKING FOR CLEARANCE OF COMBUSTION PRODUCTS

3.6.1 Close all doors and windows in the room. Remove the dress guard.

3.6.2 Light the fire and adjust to the maximum heat input position. After 5 minutes hold the smoke match as shown in figure 20. Whilst holding the smoke match in the correct position, approximately 5mm below and inside the lower edge of the centre of the canopy. Ensure that most of the smoke is drawn into the flue aperture. If in doubt repeat the exercise after a further 5/10 minutes.

Note:- It is recommended that the smoke match is fitted into an approved smoke match holder, when checking for clearance of combustion products.

Fig. 20

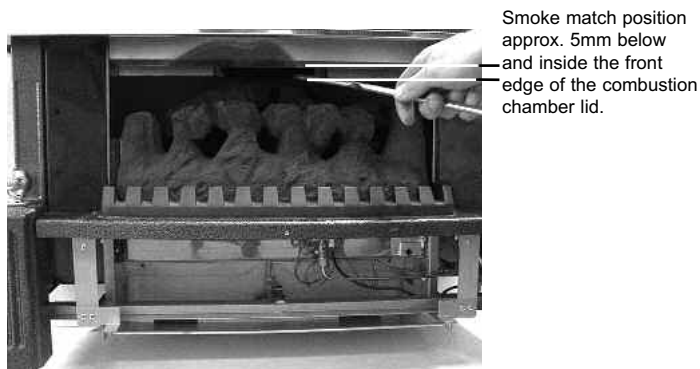

3.6.3 If the smoke is not drawn into the flue aperture, remove the efficiency baffle from the spigot, then repeat the procedure as detailed in section 3.6.2 & 3.6.3 above. If the spillage test is still not successful, then carry out procedure as detailed overpage.

If there is an extractor fan fitted in a joining room, then the spillage test must be repeated with the fan switched on and running at maximum speed. All interconnecting doors must be opened in accordance with the latest issue of BS 5440.

IF SPILLAGE IS DETECTED

The cause must be discovered and the fault corrected. If the fault cannot be corrected disconnect the appliance from the gas supply and seek expert advice. Possible causes of spillage from the appliance (if the efficiency baffle has been removed) are :- chimney restriction, down draught or insufficient air supply to the room.

- 3.6.4 After ensuring that the fire is safe to use it should be left on “High” position to fully warm up. During this time a slight odour may be noticed, this is due to the “newness” of the fire and will soon disappear.

3.7 FINAL CHECK

- 3.7.1 Refit the dress-guard if it has not already been re-fitted.
- 3.7.2 Recheck the operation of the fire on all settings.
- 3.7.3 Make sure that the user knows how to operate the fire and refer them to this manual.
- 3.7.4 Inform the user that the model number for ordering parts is shown on the rating plate. The rating plate can be viewed at the bottom left hand side of the rear panel, when the bezel and heat shield are removed.
- 3.7.5 Inform the user the fire should be serviced annually for continued safe operation.
- 3.7.6 Hand this instruction booklet to the customer.

IF A REPLACEMENT FUELBED IS REQUIRED :-

When replacing the fuelbed remove the old fuelbed and discard it. Fit a complete fuelbed of the correct type.

To ensure that the release of fibres from these R.C.F (Refractory Ceramic Fibre) articles is kept to a minimum, during installation and servicing we recommend that you use a HEPA filtered vacuum to remove any dust accumulated in and around the appliance before and after working on the appliance. When replacing these articles we recommend that the replaced items are not broken up, but are sealed within heavy duty polythene bags, clearly labelled as “RCF waste”. RCF waste is classed as a “stable”, non reactive hazardous waste and may be disposed of at a landfill licensed to accept such waste Protective clothing is not required when handling these articles, but we recommend you follow the normal hygiene rules of not smoking, eating or drinking in the work area, and always wash your hands before eating or drinking.

MAINTENANCE INSTRUCTIONS

Servicing Notes

Servicing should be carried out annually by a competent person such as a **GAS SAFE** registered engineer.

The service should include visually checking the chimney and fire opening for accumulations of debris and a smoke test to check for positive up-draught in the chimney.

The condition of the fuelbed should be checked and if necessary the whole set should be replaced with a genuine replacement set.

After any servicing work a gas tightness test must always be carried out.

4.1 GENERAL ACCESS FOR SERVICING

4.1. TO REMOVE THE UPPER CANOPY

4.1.1 Prepare work area (lay down dustsheets etc.), Disconnect the appliance from the gas supply.

4.1.2 Remove the four canopy rear fixing screws, and the two fixing screws that are located on the underside of the canopy (see figure 21 & 22 respectively)

4.1.3 Remove the fuelbed and move to a safe place, then lift away the canopy

4.1.4 Re-assemble in the reverse order.

Fig. 21 Removing the four canopy rear fixing screws

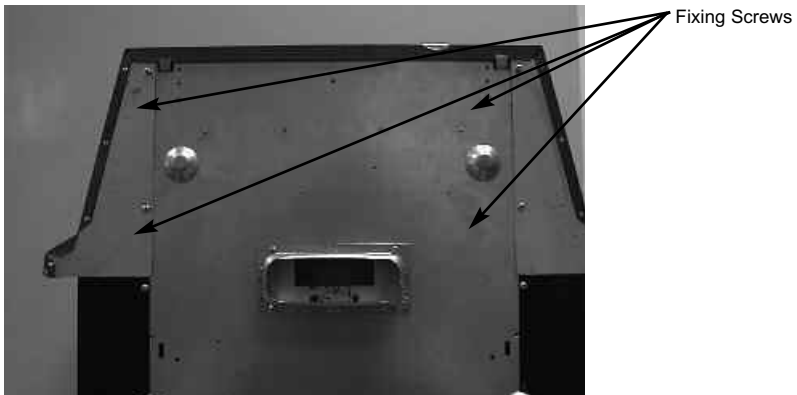
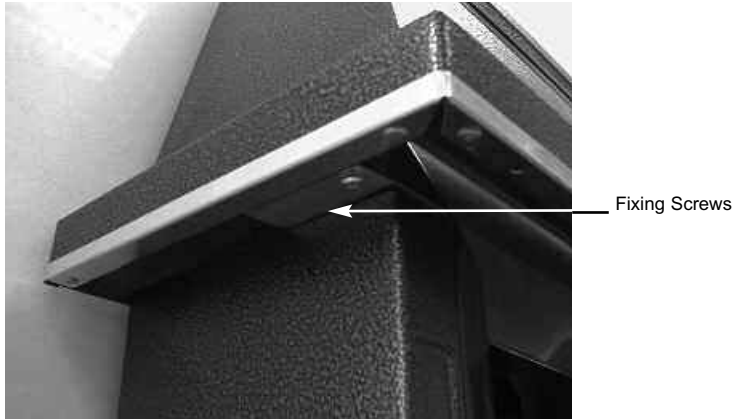

Fig. 22 Removing the Upper Outer Case Fixing Screws



4.2 REMOVING THE BURNER ASSEMBLY FROM THE FIRE

- 4.2.1 Disconnect the appliance from the gas supply. Remove the front panel by unscrewing the retaining nuts below the front panel as shown in figure 23 below.

Fig. 23

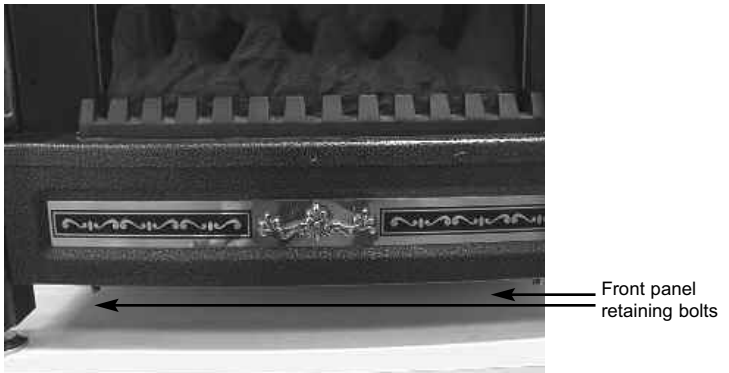

- 4.2.2 Remove the front bezel by unscrewing the 2 retaining screws, as shown in figure 24 overpage.

Fig. 24



Front bezel retaining screws (1 off each side)

4.2.3 Remove the black painted heat shield by removing the L/H/S & R/H/S retaining screws.

4.2.4 Remove the four burner retaining screws, disconnect the pilot assy. and lift the burner clear

4.3 REMOVING THE REMOTE GAS VALVE FROM THE FIRE

4.3.1 Disconnect the appliance from the gas supply.

4.3.2 Remove the upper canopy as shown in section 4.1

4.3.3 Remove the ashpan cover which is held in position by two nuts at the base. Remove the control cover which is held in place by magnets a shown below in figure 25.

Fig. 25

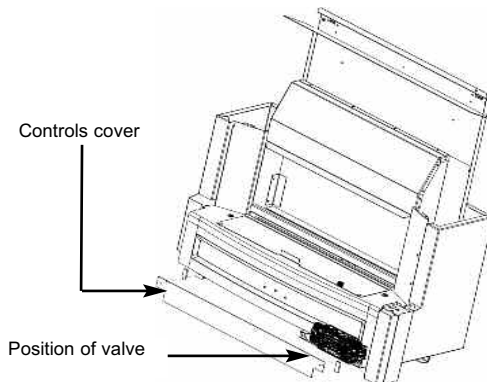

Remove the right hand side panel as shown below in figure 26.

Fig. 26

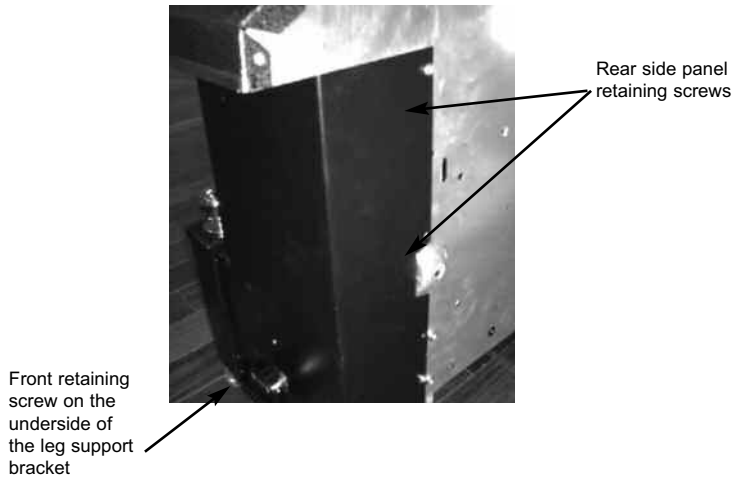

4.3.4 Disconnect the pipes to the remote gas control control valve and disconnect the thermocouple connection.

4.3.5 Replace in reverse order and carry out a gas tightness test.

4.4 REMOVING THE ODS- PILOT ASSEMBLY

Note : Because this appliance is fitted with an atmosphere sensing ODS-pilot it is not possible to replace the thermocouple separately, because the thermocouple position is factory set to a tight tolerance. Any replacement of parts on the pilot requires a complete new pilot assembly.

4.4.1 Remove the front panel and front bezel as described in section 4.2
Remove the black painted heat shield by removing the L/H/S & R/H/S retaining screws.

4.4.2 Unscrew the pilot fixing screws. These can be accessed from the front of the appliance with the front panel and bezel removed.

4.4.3 Remove the thermocouple wires as described in section 4.3.4

4.5 PARTS SHORTLIST

Replacement of parts must be carried out by a competent person such as a GAS SAFE registered gas installer. The part numbers of the replaceable parts are as follows, these are available from your local Flavel stockist, whose details may be found on the BFM Europe website, address as shown on the back page of this book.

Ignition wire remote models	B-34690
ODS pilot assembly	B-170240
RC gas control valve	B-160780
RC handset	B-168970
Fuelbed set	B-66010

SECTION FIVE - USER INSTRUCTIONS

5.1 INSTALLATION INFORMATION

CONDITIONS OF INSTALLATION

It is the law that all gas appliances are installed only by a competent (e.g. Registered) Installer, in accordance with the installation instructions and the Gas Safety (Installation and Use) Regulations 1998. Failure to install appliances correctly could lead to prosecution. It is in your own interest and that of safety to comply with the law.

The fire may be fitted below a combustible shelf provided that the shelf is at least 200mm above the top of the appliance and the depth of the shelf does not exceed 150mm.

The fire may be installed below combustible shelves which exceed 150mm deep providing that the clearance above the fire is increased by 15mm for each 25mm of additional overhang in excess of 150mm.

If this appliance is fitted directly on to a wall without the use of a fireplace or surround, soft wall coverings such as wallpaper, blown vinyl etc. could be affected by the heat and hot convection air and may discolour or scorch. This should be considered when installing or decorating.

The Model number of this appliance is as stated on the rating plate affixed to the rear left hand corner of the fire and the appliance is manufactured by:-

BFM Europe Ltd
Trentham Lakes
Stoke on Trent
ST4 4TJ

ABOUT YOUR NEW FLAVEL REGENT LFE GAS FIRE

The Flavel Regent LFE coal effect gas fire incorporates a unique and highly developed fuel bed which gives the realism of a loose coal layout combined with realistic flames and glow. The use of durable ceramic material in the construction of the fuelbed components ensures long and trouble free operation.

Please take the time to fully read these instructions as you will then be able to obtain the most effective and safe operation of your fire.

IMPORTANT SAFETY INFORMATION

WARNING

This is a heating appliance and as with all heating appliances a fireguard should be used for the protection of children, the elderly and infirm. Fireguards should conform to B.S. 8423 : 2002 (Fireguards for use with gas heating appliances).

It is important that this appliance is serviced at least once a year by a GAS SAFE registered gas installer. During the annual service, replacement of the Oxy-pilot must be carried out. **This is a condition of the manufacturers guarantee.**

Any debris or deposits should be removed from the fuel bed from time to time. This may be carried out by referring to the cleaning section as described later in this book.

Only complete and genuine replacement fuel-bed sets must be used.

Always keep furniture and combustible materials well clear of the fire and never dry clothing or items either on or near to the fire. Never use aerosols or flammable cleaning products near to the fire when it is in use.

The ceramic fuel bed remains hot for a considerable period after use and sufficient time should be allowed for the fire to cool before cleaning etc.

ABOUT YOUR NEW FLAVEL REGENT LFE GAS FIRE

The Flavel Regent L.F.E. gas fire incorporates a unique and highly developed fuelbed which gives good flame aesthetics whilst maintaining reasonable running costs.

Please take the time to fully read these instructions as you will then be able to obtain the most effective and safe operation of your fire.

IMPORTANT SAFETY INFORMATION

WARNING

This appliance has a naked flame and as with all heating appliances a fireguard should be used for the protection of children, the elderly and infirm. Fireguards should conform to B.S. 8423 : 2002 should be fitted. (Fireguards for use with gas heating appliances).

It is important that this appliance is serviced at least once a year by a registered gas installer and that during the service the fire is removed from the fire opening and the chimney or flue visually checked for fallen debris or blockages which must be removed. The chimney should also be checked to ensure clearance of flue products. During the annual service, replacement of the Oxypilot must be carried out as a condition of the manufacturers guarantee. **After installation or during servicing a spillage test must always be carried out.**

Rubbish of any type must NEVER be thrown onto the ceramics, this could affect safe operation and damage the fire.

Any debris or deposits should be removed from the fuel-bed from time to time. This may be carried out by referring to the cleaning section as described later in this book.

Only the correct type of fuelbed ceramics must be used and only complete and genuine replacement sets must be sourced from BFM Europe Ltd.

Always keep furniture and combustible materials well clear of the fire and never dry clothing or items either on or near to the fire. Never use aerosols or flammable cleaning products near to the fire when it is in use.

The ceramic fuel-bed remains hot for a considerable period after use and sufficient time should be allowed for the fire to cool before cleaning etc. The fire must only be operated with the dress guard supplied with the fire

5.2 OPERATING THE FIRE - REMOTE CONTROL MODELS

- 5.2.1 Ensure valve power isolation switch is in the on position - see figure 6
Hold the handset with one hand ensuring your hand is wrapped around the back and that your hand is in contact with both sides of the handset.
The green light of the “unlock” symbol should light. See figure 1 below.

Fig. 1

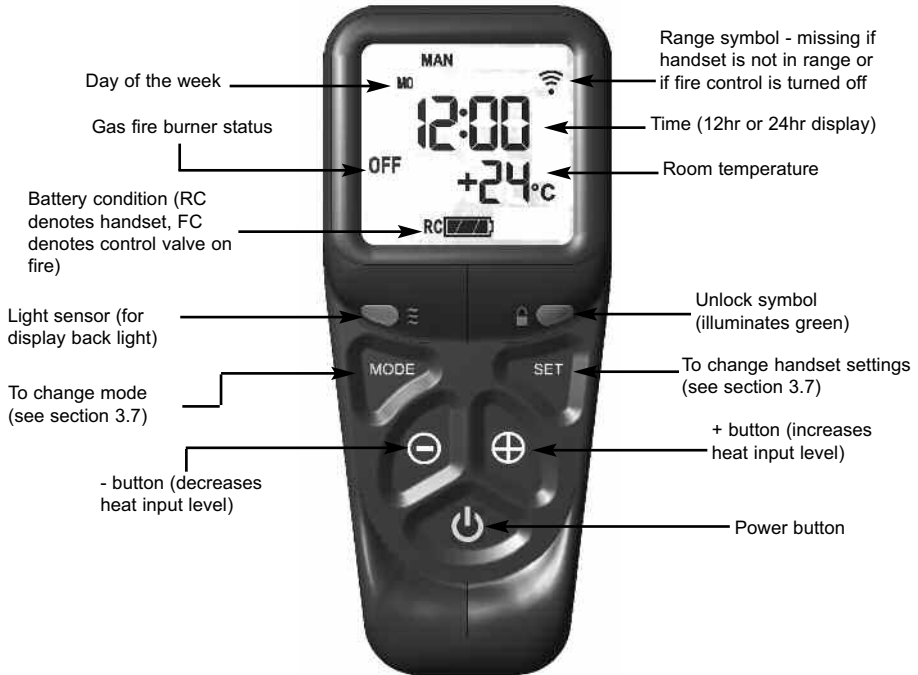

- 5.2.2 Press and hold the power button continuously until the word “PILOT” appears at the bottom left of the display as shown overpage in figure 2, (this typically takes two seconds). The burner will now light at maximum heat input level and will display “MAX” in the bottom left hand side of the display as shown in figure 3 overpage. **For most efficient performance leave the fire on high when lighting from cold for ten minutes.**

NOTE : If the power button is pressed for too long or too short a time or the grip on the handset is not firm or is released too soon, the lighting sequence will be interrupted and not complete. The reason for the remote control having this strict start sequence is for safety reasons so that the starting operation of the fire will be most unlikely to be done other than intentionally by an adult.

Fig. 2 - "PILOT" displayed



"PILOT" displayed on handset during ignition sequence (typically takes two seconds)

Fig. 3 - "MAX" & large flame symbol displayed

"MAX FLAME" displayed on handset when burner is lit to maximum rate



5.2 OPERATING THE APPLIANCE - REMOTE CONTROL MODELS (CONTINUED)

- 5.2.3 To decrease the heat input level of the burner hold the handset as described in section 5.2.1 to unlock the keypad then press and release the - button. Pressing and releasing the - button will lower the heat input level one step at a time. Pressing the - button continuously will move the heat input level to the minimum, see figure 4 below.

Fig. 4



- 5.2.4 To increase the heat input level of the fire's burner hold the handset as described in section 5.2.1 to unlock the keypad then press and release the + button. Pressing and releasing the + button will increase the heat input level one step at a time. Pressing the + button continuously will move the heat input level to the maximum.
- 5.2.5 To turn the fire off hold the handset as described in section 5.2.1 to unlock the keypad then press and release the power button. The burner will go out.

5.2.6

If you are not intending to use the fire for a long period (i.e. over the summer months) the battery life can be extended by sliding the power isolator switch to the left (to the “0” position away from the “1” position) on the valve itself, which is located under the front right of the fire behind the removeable cover plate on the top left corner of the control valve.

5.2.7

In the event of loss of the remote handset, as a backup the fire can be controlled from the valve, which is located behind the ashpan cover on the fire, see section 5.3 for full manual operating instructions. If your fire does not operate manually please consult the troubleshooting chart on the rear page of this manual.

5.2.8

If the handset is misplaced you can “page it” by pressing the (+) button only on the control valve on the fire for a period of 5 seconds. The handset will flash and make an audible noise to help you locate it. Once you find the handset with one hand ensure your hand is wrapped around the back and that your hand is in contact with both sides of the handset then the audible noise will cease. The flashing and sound will last for 60 seconds each time the handset is paged as described. If not found in 60 seconds page the handset again until located.

IMPORTANT NOTE : THE BATTERIES SHOULD BE REPLACED WITH GOOD QUALITY ALKALINE BATTERIES WHEN REQUIRED, THE BATTERY LIFE IS EXPECTED TO BE A MINIMUM OF 12 MONTHS WITH NORMAL USAGE. FOR BEST PERFORMANCE BFM EUROPE RECOMMEND THE USE OF ENERGIZER BATTERIES WITH IT’S PRODUCTS.

5.3 MANUAL OPERATION OF THE FIRE

5.3.1 These products can therefore be operated manually should the need arise. The control valve is located at the base of the fire, remove cover plate (held by magnets) for access as shown below in figure 5.

Fig. 5

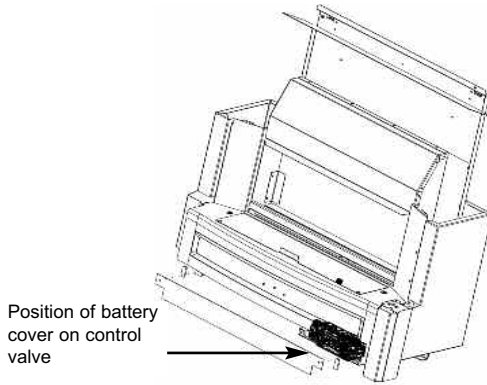

5.3.2 Ensure that the power isolation switch is in position "1" and the power indicator light is illuminated (red) as shown in figure 6 below.

Fig. 6

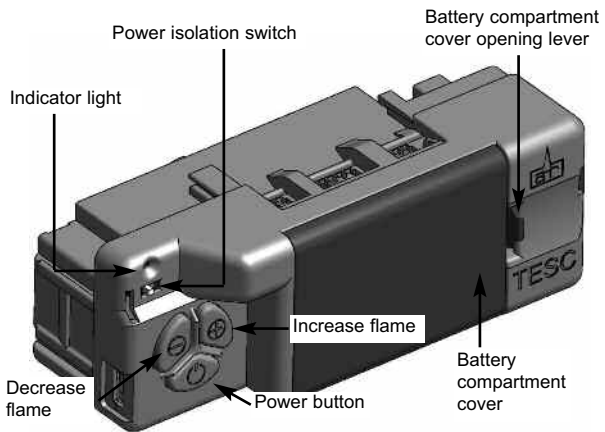

- 5.3.3 To operate the fire press and hold the “power” button as shown in figure 2 on the previous page for two seconds, release as soon as the red indicator light in figure 2 on the previous page illuminates. The burner will start its ignition sequence and light to the maximum heat input level.
- 5.3.4 To reduce the heat input, press and release the (-) button to lower the heat input level one step at a time. Pressing the (-) button continuously will move the heat input level to the minimum.
- 5.3.5 To turn the fire off, press the power button and the burner will stop.
- 5.3.6 **If you are not intending to use the fire for a long period (i.e. over the summer months) the battery life can be extended by sliding the power isolator switch to the left (to the “0” position away from the “1” position) on the valve itself, which is located under the front right of the fire behind the removeable cover plate on the top left corner of the control valve.**

5.4 REPLACING THE BATTERIES ON REMOTE CONTROL MODELS

- 5.4.1 Remove the ashpan cover, locate the control valve battery cover at the right hand side of the burner, slide the power isolator switch to the “0” position (to the left).
- 5.4.2 Remove the battery cover and replace the 3 off AA batteries with good quality Alkaline items, BFM Europe recommend the use of “Energizer” batteries. **It is important that only an alkaline battery is used, otherwise premature battery failure and leakage may result.**
- 5.4.3 Replace the battery cover and turn the power isolator switch to the “1” position (to the right).
- 5.4.4 Replace the ashpan cover and operate the fire as normal.
- 5.4.5 On remote control models only fit two off AA batteries to the handset in the direction shown inside the handset moulded into the plastic.

5.5 SETTING THE TIME, DATE & TEMPERATURE ON THE REMOTE HANDSET

- 5.5.1 Fit the 2 off AA batteries to the handset by removing the cover on the rear of the handset and inserting the batteries, ensure the correct +/- polarity is observed. Following insertion of the batteries the screen displayed will be as shown below in figure 7.

Fig. 7



- 5.5.2 Hold the handset with one hand ensuring your hand is wrapped around the back and that your hand is in contact with both sides of the handset. The green light of the “unlock” symbol should light and the screen displayed will be as shown overpage in figure 8.
- 5.5.3 The “H” symbol as indicated in figure 8 overpage indicates that the timer can now be set in either 24hr or 12hr mode. Press the + or - buttons on the handset to toggle between the two settings, figure 8 overpage displays the 24hr mode.

Fig. 8



5.5.4 When the 24hr or 12hr time display option has been chosen and you are ready to confirm the setting you want press the SET button on the handset to progress to setting the day of the week as shown overpage in figure 9.

5.5.5 Press and release the + and - buttons on the handset until the correct day of the week is shown on the handset display

Mo = Monday
Tu = Tuesday
We = Wednesday
Th = Thursday
Fr = Friday
Sa = Saturday
Su = Sunday

5.5.6 Press SET to accept the day of the week and progress to setting the hour of the day.

Fig. 9



5.5.7 As shown above in figure 9 the time on the handset can now be set by using the + and - buttons to change the hour to the correct hour then press SET to store and to move to setting the minute. Repeat this process for setting the minute to the correct minute then press SET to store.

5.5.8 The handset will then display the temperature setting screen as shown overpage in figure 10, the option to choose either Celsius or Fahrenheit can be chosen, these settings are shown as either C or F. Use the + and - buttons to toggle between these two options then press SET to store. The important settings have now been completed so press and hold the SET button for a few seconds and this will exit the set-up menu.

Fig. 10



5.5.9 The control is now ready for use with the burner.

5.5.10 If the handset is misplaced you can “page it” by pressing the (+) button only on the control valve on the fire for a period of 5 seconds. The handset will flash and make an audible noise to help you locate it. Once you find the handset with one hand ensure your hand is wrapped around the back and that your hand is in contact with both sides of the handset then the audible noise will cease. The flashing and sound will last for 60 seconds each time the handset is paged as described. If not found in 60 seconds page the handset again until located.

5.6 ADVANCED SETTINGS MENU OF THE REMOTE CONTROL

5.6.1 Snooze mode in manual operation

- 5.6.1.1 Snooze mode is a time period which can be set which will turn the fire automatically off after a certain time period has elapsed.
- 5.6.1.2 Hold the handset with one hand ensuring your hand is wrapped around the back and that your hand is in contact with both sides of the handset. The green light of the “unlock” symbol should light. The snooze time period can be set either before or during manual operation of the fire.
- 5.6.1.3 With the handset held as described above, press the mode button to scroll through the functions until the symbols MAN and Zzz are flashing at the top of the display as shown below in figure 11.
- 5.6.1.4 Press and release the set button and this will put the control into the manual snooze mode.
- 5.6.1.5 The default time period in snooze mode is 1:00 hour.

Fig. 11



5.6.1.6 Pressing the set button again will now show you the snooze time period remaining. The snooze time period can be adjusted by pressing the + or - buttons on the handset. This time period can be set ranging from 1 minute to 4:00 hours.

5.6.1.7 To adjust the snooze period, hold the handset with one hand ensuring your hand is wrapped around the back and that your hand is in contact with both sides of the handset. The green light of the “unlock” symbol should light. Press the set button and the screen will show how long is left of the snooze period as shown below in figure 12.

Fig. 12



5.6.1.8 To adjust the snooze period use the + and - buttons to increase or decrease the snooze period for any period between 1 minute and 4:00 hours.

5.6.1.9 When the correct snooze period is indicated on the handset, press the set button to store the required time period, or alternatively the handset can be left for a few seconds and the period will be stored automatically.

5.6.1.10 When the countdown timer for the snooze period has reached zero the fire will turn off (as if you had turned the fire off manually).

5.6.2 Thermostatic mode

PLEASE NOTE : Thermostatic mode of this fire will only allow regulation of the room temperature by the fire when it has been already lit via manual operation of the handset. It will not allow the fire to light automatically due to low ambient room temperature and should therefore not be relied upon for frost protection purposes.

5.6.2.1 Hold the handset with one hand ensuring your hand is wrapped around the back and that your hand is in contact with both sides of the handset. The green light of the “unlock” symbol should light.

5.6.2.2 With the handset held as described above, press and release the mode button several times as necessary until the display has the thermometer symbol flashing at the top of the display. Press the set button to enter this mode, as shown below in figure 13.

Fig. 13



5.6.2.3 Press the set button again to see the temperature setting that is set (the default is 24 degrees celsius). If a different set temperature is required, whilst the display is showing this set temperature, press the + and - buttons to alter this setting, press the set button to store the required temperature, or alternatively the handset can be left for a few seconds and the temperature will be stored automatically.

5.6.2.4 If at any time the power button is operated during thermostat mode the control will cancel any thermostat operation and return the control to manual mode.

5.6.2.5 **IMPORTANT NOTE : Thermostat mode will not light the fire automatically and will only regulate between the maximum and minimum burner setting. The fire must be lit manually via the handset and then you enter thermostat mode as described in this section and set the temperature. When no longer requiring thermostat mode turn off the burner and the handset will return to manual mode.**

5.7 CLEANING - WARNING

Before attempting any cleaning operation ensure that the fire has been allowed to fully cool.

5.7.1 CLEANING THE FUELBED CERAMICS

We do not recommend regular cleaning of the fuelbed ceramics as these are fragile and damage may result. **None of these parts must be washed or exposed to any cleaning agents or water.**

Any damaged parts must be replaced by contacting your dealer or telephoning BFM Europe Ltd. on the number stated on the rear cover of this book. The fuelbed ceramics must only be replaced with a complete and genuine replacement set and the fire must never be run with the wrong number or damaged fuelbed ceramics. The ceramic fuelbed must be carefully re-assembled as stated in the following section.

5.7.2 CLEANING THE DRESSGUARD OR REFLECTOR.

Remove the dress-guard by pulling the location wire out at the top, and lifting away. See figure 14 below.

Clean the dress-guard or reflector by wiping with a damp cloth, and polish with a dry duster. **DO NOT USE ABRASIVE CLEANERS**

5.7.3 CLEANING THE CASE.

Dusting is normally all that is required. But where extra cleaning is necessary, use a damp cloth.

Fig. 14

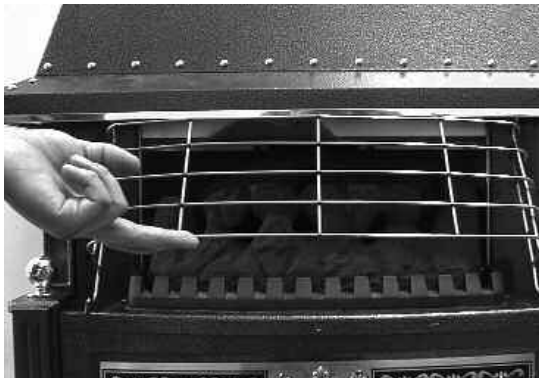

5.8 REMOVAL / REFITTING OF THE FUELBED CERAMICS

- 5.8.1 Fit the rear fuelbed section to the combustion chamber, locating behind the support bracket as indicated below in figure 15.

Fig. 15

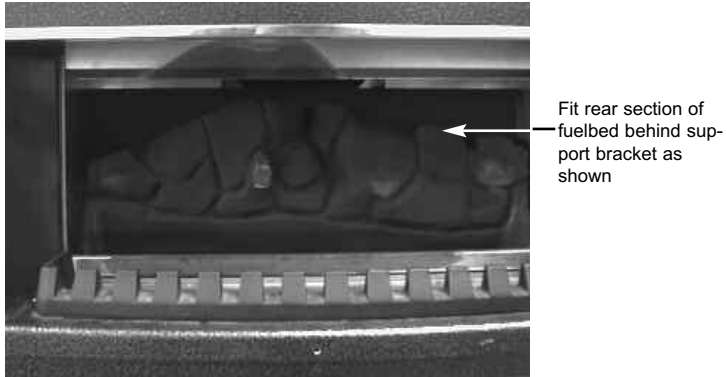

- 5.8.2 Fit the front section of the fuelbed to the combustion chamber, locating behind the front casting as shown overpage in figure 16.

Fig. 16

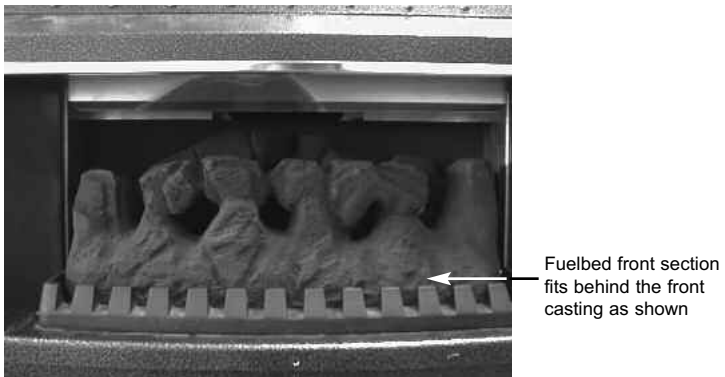

- 5.8.3 Refit the dress guard.

5.9 USER REPLACEABLE PARTS

Fuelbed set

B-66010

Due to our policy of continual improvement and development the exact accuracy of descriptions and illustrations cannot be guaranteed.

TROUBLE SHOOTING ADVICE FOR REMOTE CONTROL MODELS PRIOR TO REQUESTING A SERVICE CALL

Please locate the Indicator light on the control valve under the removeable cover plate at the front right hand side of the fire (see figure 6 on page 41), if it shows **any** of the following flashing sequences then the problem requires the batteries in the control valve and / or handset changing, **be advised that service calls as a result of batteries requiring being changed in the product or handset are chargeable.**

- a) If the red indicator light flashes **ONCE** every ten seconds the batteries in the control valve require changing, see section 5.4
- b) If the red indicator light flashes **TWICE** every ten seconds the batteries in the handset require changing, see section 5.4
- c) If the red indicator light flashes **THREE** times every ten seconds the batteries in the control valve and the handset require changing, see section 5.4

If these red indicator light flashes are ignored then eventually this will show as a flash every second and your fire will cease to operate until the batteries are changed.

If a permanent red indicator light is shown after attempting to ignite the fire this signifies no spark or no gas at the pilot and therefore a service call will be required to diagnose the fault.

PLEASE ENSURE THIS ADVICE IS FOLLOWED TO AVOID BEING CHARGED FOR A SERVICE CALL AS A RESULT OF BATTERIES REQUIRING TO BE CHANGED.

Part No. B-1004039
Issue 1



At the heart of your home

BFM Europe Ltd
Trentham Lakes
Stoke-on-Trent
Staffordshire
ST4 4TJ

www.bfm-europe.com

Telephone - General Enquiries : (01782) 339000
Telephone - Service : (01782) 339008